

# 500DA

## SD-SDI Reclocking Distribution Amplifier



The 500DA Reclocking Distribution Amplifier provides inexpensive distribution of your SMPTE 310M and SMPTE 259M serial digital video signal at rates of 19.4Mb/s and 143Mb/s to 540Mb/s. Ideal in applications where a large quantity of outputs are required, the DA features an auto-equalized input with nine isolated reclocked outputs.

The input also features an isolated return that is capacitively coupled to ground. The 500DA has been designed for use as a SMPTE 310M (19.4Mb/s), DVB-ASI or SMPTE 259M distribution product. SMPTE 310M support is selected by setting a rate select jumper.

The 500DA is housed in the 3RU 500FR **exponent** frame that will hold up to 16 modules.

### Features & Benefits

- Normal mode for SMPTE 259M (143Mb/s to 540Mb/s) or DVB-ASI signals autodetects correct bitrate
- Jumper Selectable mode for SMPTE 310M (19.4Mb/s)
- Fully hot-swappable from front of frame with no BNC disconnect required
- Independent isolated output drivers to ensure no cross channel loading effects (i.e. no need to terminate unused outputs)
- Outputs maintain polarity from input to output for DVB-ASI applications
- Tally output on Frame Status bus upon loss of input signal for quality monitoring
- VistaLINK® -capable for remote monitoring via SNMP (using VistaLINK® PRO) when installed in 500FR frame with 500FC VistaLINK® Frame Controller

### Outputs

- 9 reclocked outputs
- Return loss > 15dB up to 540Mb/s
- Wideband jitter < 0.2 UI

### Card Edge LEDs

- Reclocker rate (5 LEDs)
- Reclocker Locked
- Max. Equalization Warning
- 310M Reclocker Enable
- Module Health Status

### Input

- SMPTE 259M-A, B, C, D (143Mb/s to 540Mb/s), DVB-ASI, SMPTE 310M (19.4Mb/s) (jumper selectable)
- Return loss > 15dB up to 540Mb/s
- 440m auto eq. at 270Mb/s (Belden 1694A)

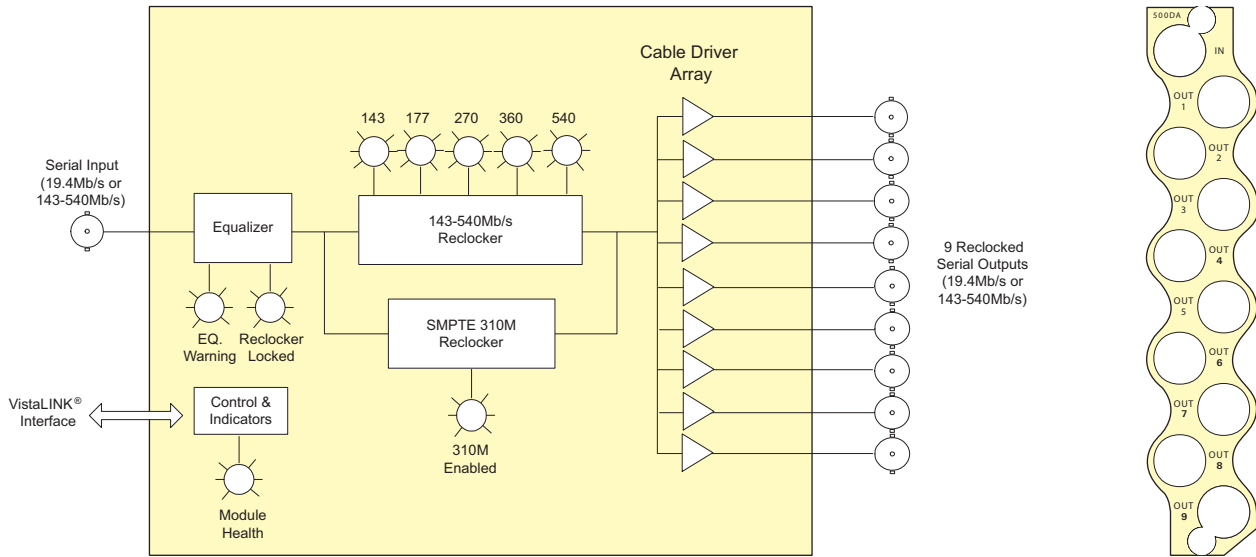

### Specifications

#### Serial Video Input:

Standard:  
 259 Mode: SMPTE 259M-A, B, C, D (143 to 540Mb/s) or DVB-ASI  
 310 Mode: SMPTE 310M (19.4Mb/s)  
 Connector: BNC per IEC 61169-8 Annex A  
 Equalization: Automatic to 440m @ 270Mb/s with Belden 1694A  
 Return Loss: > 15dB up to 540Mb/s

#### Serial Video Output:

Number of Outputs: 9 Reclocked  
 Connector: BNC per IEC 61169-8 Annex A  
 Signal Level: 800mV nominal  
 DC Offset: 0V ±0.5V  
 Rise and Fall Time: 470ps nominal  
 Overshoot: < 10% of amplitude  
 Return Loss: > 15dB up to 540Mb/s  
 Wideband Jitter: < 0.2 UI

#### Electrical:

Voltage: +12V DC  
 Power: 6W  
 EMI/RFI: Complies with FCC Part 15 Class A EU EMC Directive

#### Physical:

Number of Slots: 1

### Ordering Information

**500DA** SD-SDI Reclocking Distribution Amplifier - (1x9)

Accessories:  
**500FC**  
**CP-2116E-H**  
**CP-2232E**

VistaLINK® Frame Controller  
 Remote Control Panel  
 Remote Control Panel

Enclosures  
**500FR**  
**5501FR**

**exponent**  
 Compact High Density Distribution Frame  
 Standalone enclosure

<https://www.go2mhz.com/product/dvb-asi-smpte-310-259m/>

